

Polestar 3

Quick guide



Available variants

Long range Dual motor (launch edition)

Long range Dual motor with Performance Pack (launch edition)

Powertrain, output, performance and range

Long range Dual motor	<u>360 kW / 489 hp / 483 bhp</u> <u>840 Nm / 620 lb-ft</u>	<u>0-100 km/h (62 mph): 5.0s</u> <u>0-60 mph: 4.8s (no rollout)</u>	<u>WLTP: up to 628 km / 390 mi</u> <u>EPA: up to 315 mi / 506 km</u>
Long range Dual motor with Performance Pack	<u>380 kW / 517 hp / 510 bhp</u> <u>910 Nm / 671 lb-ft</u>	<u>0-100 km/h (62 mph): 4.7s</u> <u>0-60 mph: 4.5s (no rollout)</u>	<u>WLTP: up to 561 km / 348 mi</u> <u>EPA: up to 279 mi / 449 km</u>

Specification and feature highlights

Platform and body style	SPA2 5-seat E-segment SUV
Exterior	SmartZone Front and rear wings, rear aero blades Infrared windshield Soft-close doors with flush glazing and retractable door handles 1.3-megapixel HD LED headlights (optional) LiDAR from Luminar (optional)
Chassis and performance	Brembo brakes Torque vectoring with dual clutches (TVDC) and rear motor disconnect Dual chamber adaptive air suspension with adjustable ride height Active dampers Adjustable suspension feel Adjustable steering feel
Connectivity and infotainment	NVIDIA DRIVE core computing Android Automotive OS with Google built-in Snapdragon Cockpit Platform from Qualcomm Technologies, Inc. 14.5" centre display 9" driver display 9.5" head-up display Bowers & Wilkins for Polestar with Dolby Atmos and 25 speakers Over-the-air updates (OTA)
Materials	Bio-attributed MicroTech Animal welfare-secured Nappa leather from Bridge of Weir Animal welfare-secured wool Recycled PET and ECONYL Repurposed aluminium



Full specifications
and product guide
available online.

Dimensions and measurements

Europe, Middle East, Asia Pacific (mm)

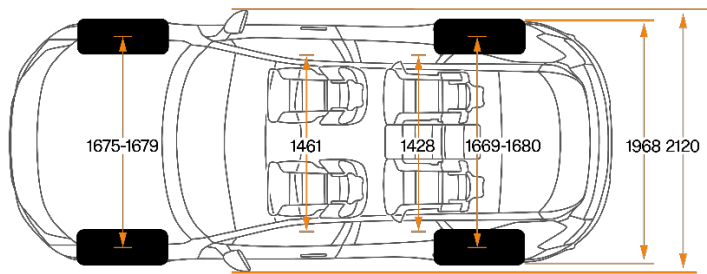
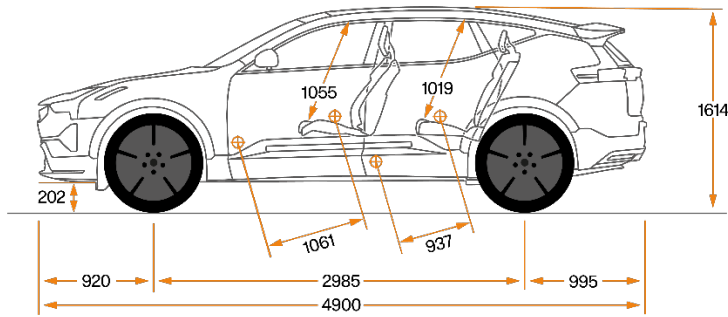

North America (inches)

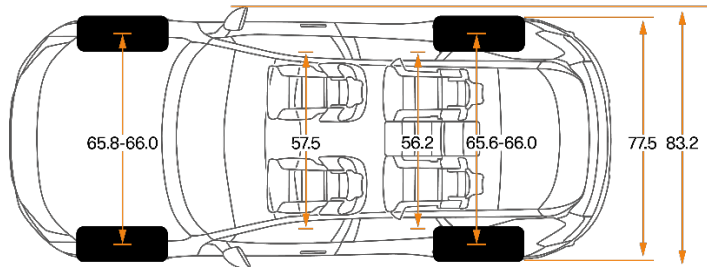
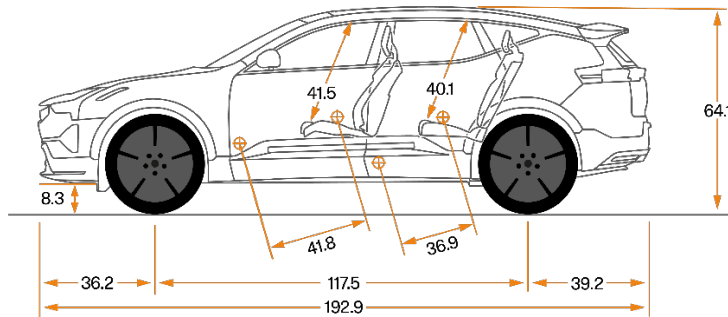

Full specifications and product guide available online.